

JUNTAS CORREDERAS SCANIA



(CON BARRON / MANGUITO CORREDERO)

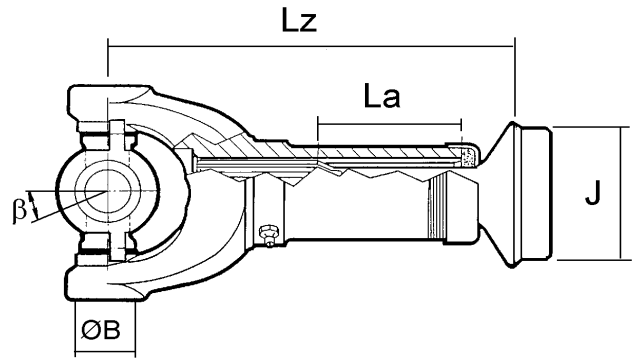

FIG. 1

TIPO DE ACOPLAMIENTO

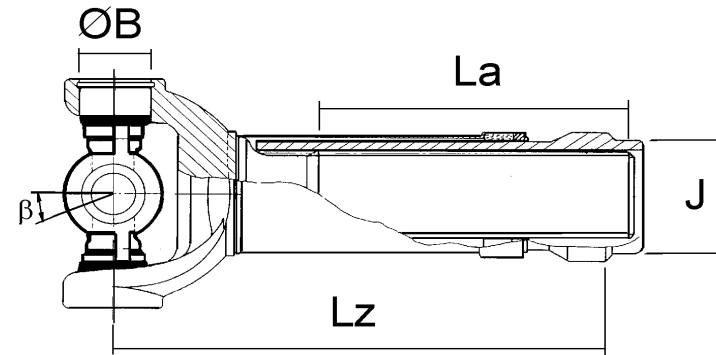
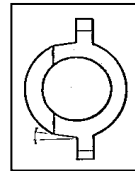

FIG. 2

REF. Cardyfren	CRUZ		SERIE	FIG.	Lz	La	Ø J	β	PARA TUBO	OBSERVACIONES.	EQUIV.		
	Ø B	D											
P300 1001	38	148	P-300	2	300	90	81	22°	90 x 5	Con manguito estriado.	P-300		
P040 1001	48	161	P-40	1	330	96	90,5	22°	100 x 5	Con barrón 24 estrias.	P-40		
P400 1001	48	161	P-400	2	330	125	90,5	22°	100 x 5	Con manguito estriado.	P-400		
P050 1001	57	164	P-50	1	335	82	90,5	22°	100 x 5	Con barrón 24 estrias.	P-50		
P500 1001	57	164	P-500	2	340	100	97,3	22°	108 x 5,5	Con manguito estriado.	P-500		
P600 1001	65	190	P-600	2	385	110	103	22°	114 x 5,5	Con manguito estriado.	P-600		