

HORQUILLAS CORREDERAS INVERTIDAS



(DE ENTRADA A CAJA DE CAMBIOS)

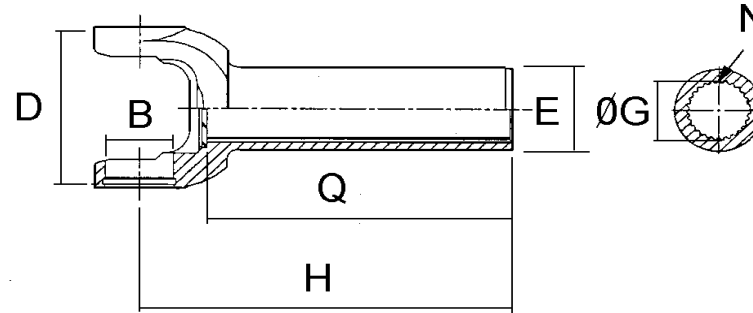

FIG. 1

REF. Cardyfren	PARA CRUZ		SERIE	FIG.	H	E	Q	Ø G	N	β	OBSERVACIONES	REF. ANTIGUA
	Ø B	D										
1100 1801	23,8	61,2	1100	1	150	35	120	25,5	24		NISSAN	I181403074
1100 1802	23,8	61,2	1100	1	115	32	81	24,6	21+2		SUZUKI SAMURAI	
1100 1803	23,8	61,2	1100	1	135	40	98	27,5	14+2		SUZUKI VITARA	
1100 1804	23,8	61,2	1100	1	135	30	115	23	18+2		FORD (Sierra / Taunus)	I1814032488
1100 1805	23,8	61,2	1100	1	135	31,1	115	22,2	16		FORD (Escort)	
1100 1806	23,8	61,2	1100	1	149	34,9	120	28,2	25		FORD	I1814031778
1100 1807	23,8	61,2	1100	1	153	38	122	30	26+1		BEDFORD	
1300 1801	27	74,6	1300	1	155	35	120	25,5	24		NISSAN	I183003040
1300 1802	27	74,6	1300	1	154	35	126	28,2	25		FORD TRANSIT	I1803501659
1300 1803	27	74,6	1300	1	135	31,1	105	22,2	16		FORD (ESCORT)	I1814032418
2780 1801	27	80		1	153	40	127	33,3	16		IVECO / VOLKSWAGEN LT (cruz para remachar)	2184103016150 EIV1001CC
1310 1801	27	81,7	1310	1	88,1	41,6	67	28,5	10	10°	CASE 231799A1	2-3-11551X
1310 1802	27	81,7	1310	1	112,5	51	86	36	21	10°	CASE (Antig. 03-510X)	2-3-9811X
1310 1803	27	81,7	1310	1	138,9	38	116,5	30	26	9°	JEEP CHEROKEE	2-3-6081X